



DC/DC converters TESD15



Features

- Class: Industrial
- Cases with mounting flanges and without flanges; or copper case (optional)
- Output current up to 3 A, output power 15 W; one, two or three output channels
- Input voltage ranges: 10,5...36 VDC, 18...75 (84) VDC
- Power density up to **1250** W/dm³
- Low profile 10 mm design
- Case operating temperature range: -60°C...+125°C
- Magnetic feedback without optocouplers
- Output voltage adjustment, remote on/off
- Max capacitance 12000 µF for U_{out}=5 VDC

Description

Ultra-compact isolated DC/DC converters (modules) are especially designed for industrial applications and harsh environment operation. These compact units (40 x 30 x 10 mm) have output power up to 15 W and wide operating temperature range between -60...+125°C. The absence of optocouplers in the converter's circuit empowers safeness during unit's entire lifetime even when performing in conditions of ionizing radiations and high temperature. These modules are available with one, two or three **galvanic isolated** channels, can be switched on/off by a signal, have full protection complex against over current, shorting and overheating and can be connected in parallel or in series.

These modules are built using especially designed electronic components and sealed with heat-conducting potting material. They have wide operating temperature range and thermal protection chip. These modules undergo special thermal and limit tests, including burn-in-tests with extreme on/off modes. They are available in metal cases with mounting flanges.

An operating unit can withstand drop of input voltage in relation to the normal input voltage, and in many cases the module is able to provide needed output power when the input voltage decreases 10-30% compared to the normative.

Upon customers' request this module can be produced in copper case with protecting coating, allowing its installation on aluminum heatsink and providing a positive effect on the modules EMC and heat transfer.

Upon customers request a low-cost version of a module is available.

Ordering information

TESD 15 - 24W S 12 - U T B

1 2 3 4 5 6 7 8

- 1 - «TESD» Series
- 2 - Output power, W
- 3 - Input voltages
 - 12W - 12 VDC (10,5...36 VDC)
 - 24W - 24 VDC (18...75 (84) VDC)
- 4 - Index of output channels quantity
 - S - one
 - D - two
 - T - three
- 5 - Nominal output voltage, VDC (two signs for a channel)
- 6 - Index of case design
 - U - metal case with flanges
 - C - metal case without flanges
- 7 - Index of operating temperature range of the case
 - T -60°C...+125°C
- 8 - Index of low cost version
 - B - Low cost version (customer-considered simplified construction)

Technical information

Standard models with one output

Module	Input voltage range	Output power	Output voltage / nominal output current	Typical efficiency ¹
TESD15-12WS05-XX	10,5...36 VDC	15 W	5 VDC / 3 A	81%
TESD15-12WS12-XX	10,5...36 VDC	15 W	12 VDC / 1,25 A	82%
TESD15-12WS15-XX	10,5...36 VDC	15 W	15 VDC / 1 A	82%
TESD15-12WS24-XX	10,5...36 VDC	15 W	24 VDC / 0,63 A	84%
TESD15-12WS27-XX	10,5...36 VDC	15 W	27 VDC / 0,56 A	84%
TESD15-24WS05-XX	18...75 (84) VDC	15 W	5 VDC / 3 A	82%
TESD15-24WS12-XX	18...75 (84) VDC	15 W	12 VDC / 1,25 A	84%
TESD15-24WS15-XX	18...75 (84) VDC	15 W	15 VDC / 1 A	84%
TESD15-24WS24-XX	18...75 (84) VDC	15 W	24 VDC / 0,63 A	86%
TESD15-24WS27-XX	18...75 (84) VDC	15 W	27 VDC / 0,56 A	86%

Modules with non-standard output voltage from 3 to 80 VDC with maximal output current up to 3 A, could be delivered by request.

¹ - Typical efficiency are stated for module which were set to an aluminum test heatsink (70x70x4mm) through a heat-conducting paste.

Standard models with two outputs

Module	Input voltage range	Output power	Output voltage / nominal output current	Typical efficiency ¹
TESD15-12WD0505-XX	10,5...36 VDC	15 W	5 VDC / 1,5 A ; 5 VDC / 1,5 A	79%
TESD15-12WD0512-XX	10,5...36 VDC	15 W	5 VDC / 1,5 A ; 12 VDC / 0,63 A	81%
TESD15-12WD1212-XX	10,5...36 VDC	15 W	12 VDC / 0,63 A ; 12 VDC / 0,63 A	81%
TESD15-12WD1515-XX	10,5...36 VDC	15 W	15 VDC / 0,5 A ; 15 VDC / 0,5 A	83%
TESD15-12WD2727-XX	10,5...36 VDC	15 W	27 VDC / 0,28 A ; 27 VDC / 0,28 A	83%
TESD15-24WD0505-XX	18...75 (84) VDC	15 W	5 VDC / 1,5 A ; 5 VDC / 1,5 A	81%
TESD15-24WD0512-XX	18...75 (84) VDC	15 W	5 VDC / 1,5 A ; 12 VDC / 0,63 A	83%
TESD15-24WD1212-XX	18...75 (84) VDC	15 W	12 VDC / 0,63 A ; 12 VDC / 0,63 A	83%
TESD15-24WD1515-XX	18...75 (84) VDC	15 W	15 VDC / 0,5 A ; 15 VDC / 0,5 A	85%
TESD15-24WD2727-XX	18...75 (84) VDC	15 W	27 VDC / 0,28 A ; 27 VDC / 0,28 A	85%

Standard models with three outputs

Module	Input voltage range	Output power	Output voltage / nominal output current	Typical efficiency ¹
TESD15-12WT051212-XX	10,5...36 B	15 W	5 VDC/1,5 A ; 12 VDC/0,31 A ; 12 VDC/0,31 A	79%
TESD15-12WT051515-XX	10,5...36 B	15 W	5 VDC/1,5 A ; 15 VDC/0,25 A ; 15 VDC/0,25 A	79%
TESD15-24WT051212-XX	18...75 (84) B	15 W	5 VDC/1,5 A ; 12 VDC/0,31 A ; 12 VDC/0,31 A	81%
TESD15-24WT051515-XX	18...75 (84) B	15 W	5 VDC/1,5 A ; 15 VDC/0,25 A ; 15 VDC/0,25 A	81%

Modules with non-standard output voltage from 3 to 80 VDC with maximal output current up to 3 A, could be delivered by request.

¹ - Typical efficiency are stated for module which were set to an aluminum test heatsink (70x70x4mm) through a heat-conducting paste.

Specifications for DC/DC converters TESD15*

Input specifications	
Input voltage range / transitional deviation, 1 sec 12W	=10,5...36 VDC / =10,5...40 VDC
Input voltage range / transitional deviation, 1 sec 24W	=18...75 VDC / =17...84 VDC
Input filter	P-type
Output specifications	
Output voltage adjustment (single-channel models only)	±5% Uout
Instability of output voltage in accordance to changing of output current from 10 to 100% for single output model	±2%
Instability of output voltage in accordance to changing of output current from 10 to 100% for dual and triple output model	±2% for chan.1, ±7% for chan.2, 3
Instability of output voltage in accordance to changing of output current for dual and triple output model with a voltage value ≥20%	±2% for chan.1, ±12% for chan.2, 3
Instability of output voltage in accordance to changing of input voltage	±0,5%
Ripple and noise (peak-to-peak) (20 MHz)	<2% Uout
Short circuit protection**	>150% Iout nom, auto repair
Overvoltage protection**	<130 % Uout
Over current protection level**	Pout ... 1.3·Pout
Remote On/Off	Shuts down outputs by applying 0...1,1VDC or connection of output «ON» and «- IN», I≤5mA
The maximum output power without the heatsink, Tamb=50°C	15 W
General specifications	
Case temperature (operating)	-60°C ...+125°C ***
Case temperature (storage)	-60°C ...+125°C
Output power derating (natural convection)	See diagram (dashed, dash-dotted curve)
Output power with heatsink	See diagram (solid curve)
High humidity	100% @35 °C
Thermal resistance case — environment without heat sink	12,5 °C/W
Conversion frequency	400-500 kHz
Insulation voltage input/output	=1500 VDC
Insulation voltage input/case	=1500 VDC
Insulation voltage output/case	=1000 VDC
Insulation voltage output/output	=500 VDC
Isolation resistance @ 500 VDC	>20 MOhm
EMC standards	EN 55022, class A; EN 55022, class B with additional filter
Safety standard	IEC/ EN 60950
Typical MTBF (Tcase = 50°C; Pout = 0,7 Pout max)	200 000 hrs
Cooling metod	Free air convection or forced air cooling
Weight (max)	30 g

* All specifications are valid for normal climatic conditions, Uin.nom., Iout.nom., unless otherwise stated.

** Parameters are stated for the information purposes and could not be used at long term work, exciding maximum output current, at work outside of a range of operating temperatures.

*** Thermal protection chip starts operating at 118°...125 °C.

Output power vs an ambient temperature at input voltage = 18...75 (84) VDC (copper case)

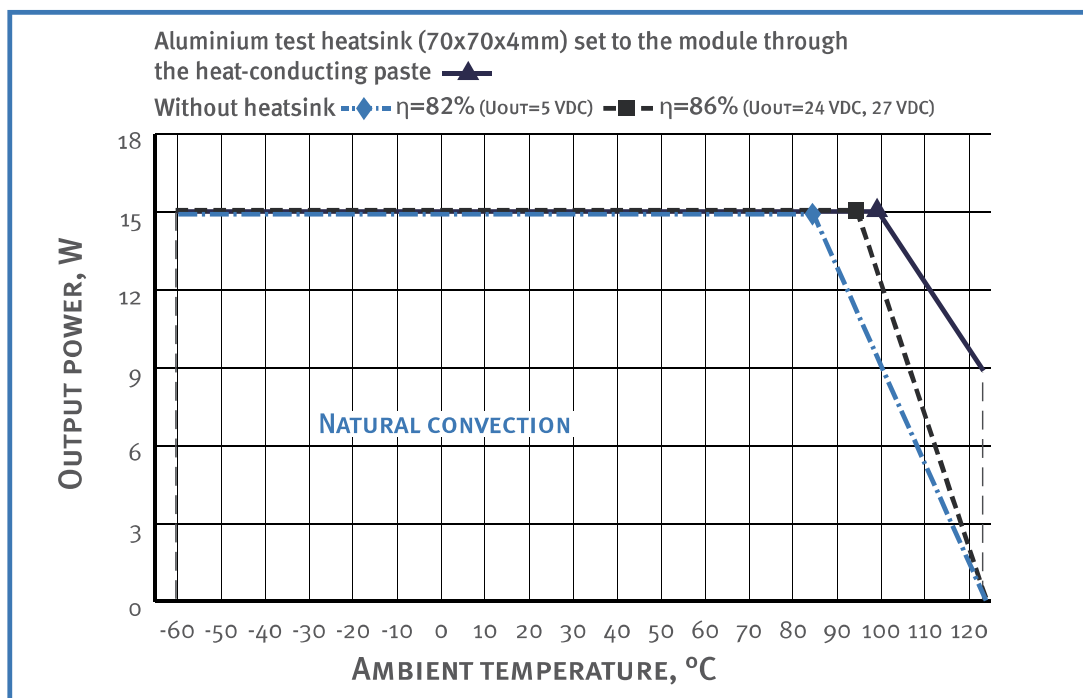

Dropping parts of the dashed and dash-dotted curves are in accordance with the **maximum temperature of the case**. Output power must not exceed the values which are limited by corresponding curve for a given ambient temperature.

At points ◆, ■ and ▲ simultaneously present several extreme worst-case conditions, such as the combination of maximum case temperature and maximum output power. Continuous module operation at these points should be avoided.

Pin out

Nº Pin	1	2	3	4	5	6	7	8	9	10
Single output	+IN	-IN	ON	-OUT	+OUT	ADJ	CASE	-	-	-
Dual output	+IN	-IN	ON	-OUT2	-OUT1	+OUT1	+OUT2	CASE	-	-
Triple output	+IN	-IN	ON	-OUT3	+OUT3	-OUT2	+OUT2	-OUT1	+OUT1	CASE

Single output model with flanges (II case type)

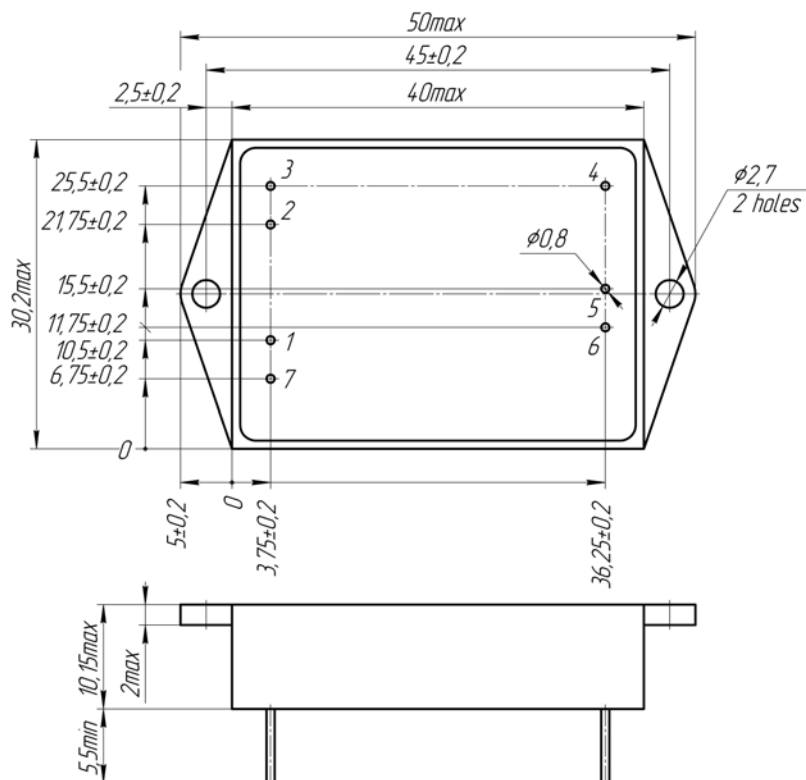

Single output model without flanges (II case type)

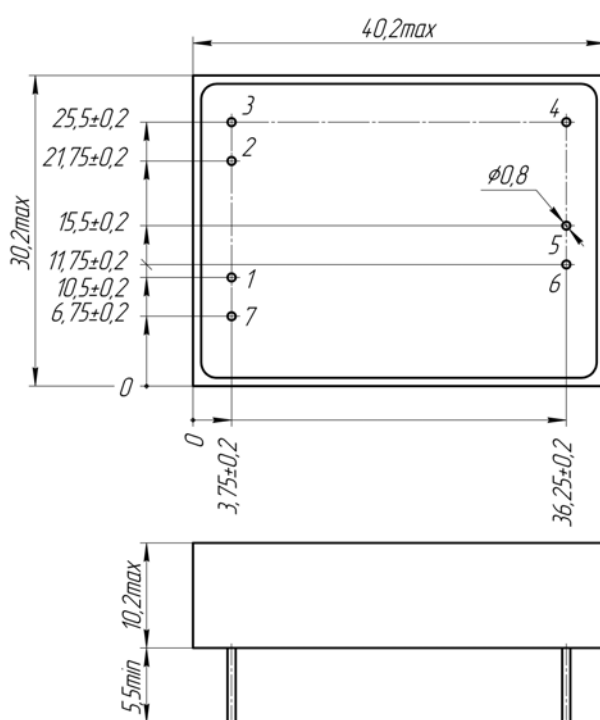

Dual output model with flanges (II case type)

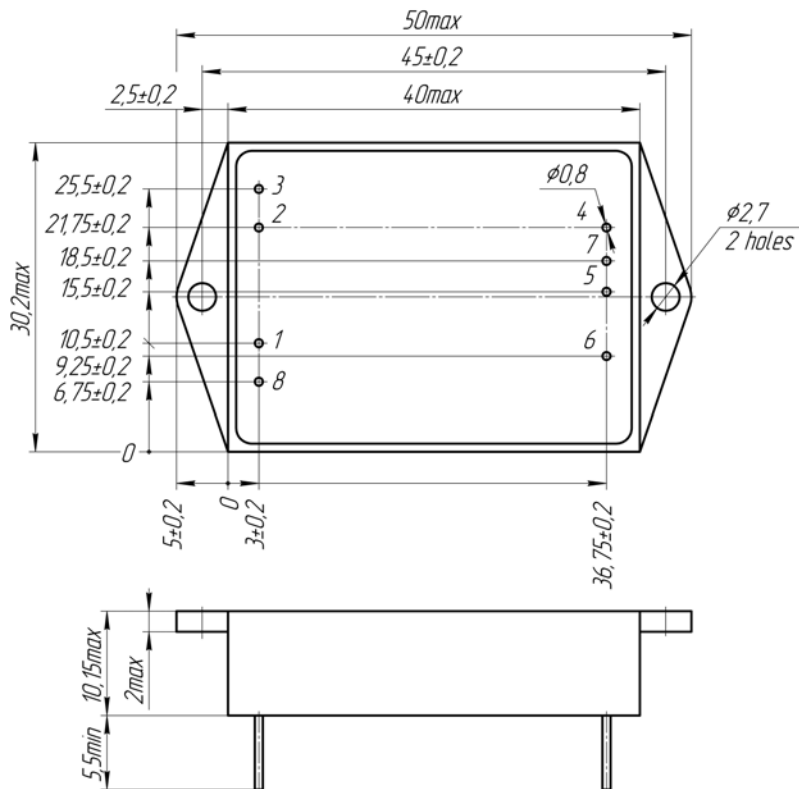

Dual output model without flanges (II case type)

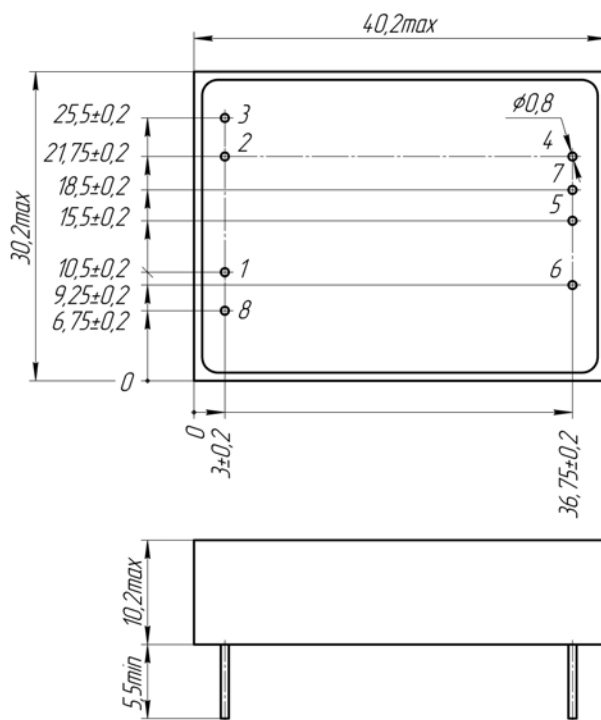

Certificates

Certificate ISO*
CE conformity declaration

*Management system of Alexander Electric is ISO certified

Note

The label with sign "remove before use" can be placed on the top surface of the module and must be removed before installation.

Please, note that all information in this material is for reference only. Further detailed information (including: additional requirements, manuals and circuit schemes) is found on our website <http://www.teslaelectric-eu.com>.

Contact information

<http://www.teslaelectric-eu.com>, e-mail: contact@teslaelectric-eu.com, phone/fax: +420 266 107 303

According to company's policy in view of constant improvements of the production design the manufacturer reserves the right to itself change the contents of promotional materials without prior notification.